

中國文化大學 九十五 學年度 第一學期 期中考 考試試卷					
考試科目	任課老師	系級	考試日期	份數	備註
應用力學	陳為仁	機一 A	95/11/16	60	Close Book

1. Determine the magnitude and direction  $\theta$  of force  $\mathbf{F}_A$  shown in Fig.1 so that the resultant force of forces  $\mathbf{F}_A$  and  $\mathbf{F}_B$  is directed along the positive x axis and has a magnitude 1500 N.

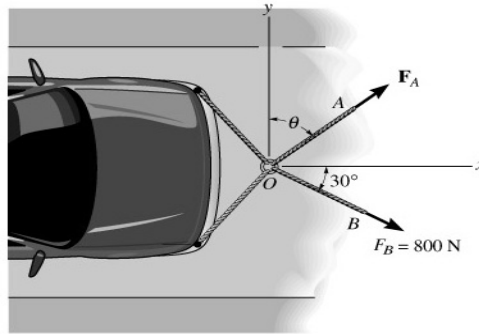

Fig. 1

2. The beam is subjected to the two forces  $\mathbf{F}_1$  and  $\mathbf{F}_2$  shown in Fig. 2. (A) Express each force in Cartesian vector form and (B) determine the magnitude and coordinate direction angles of the resultant force of forces  $\mathbf{F}_1$  and  $\mathbf{F}_2$ .

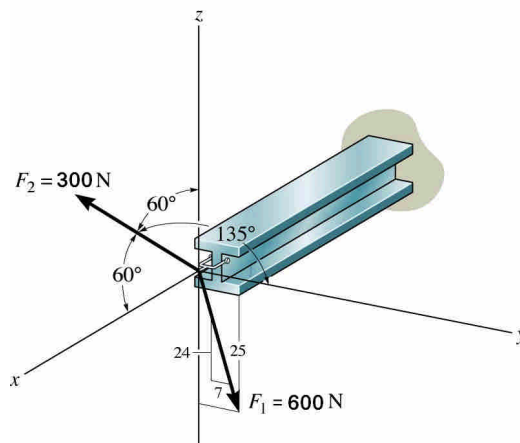

Fig. 2

3. Determine the maximum weight  $\mathbf{W}$  of the block that can be suspended in the position shown in Fig. 3 if each cord can support a maximum tension 80 N. Also, what is the angle  $\theta$  for equilibrium?

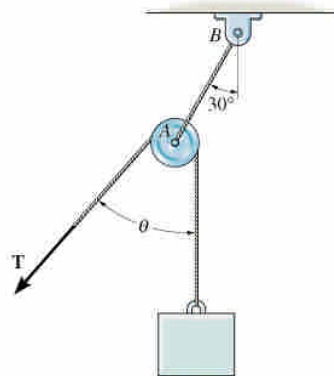

Fig. 3

中國文化大學 九十五 學年度 第一學期 期中考 考試試卷					
考試科目	任課老師	系級	考試日期	份數	備註
應用力學	陳為仁	機一 A	95/11/16	60	Close Book

4. The three cables are used to support the 800-N lamp in Fig. 4. (A) Draw a free body diagram at the knot A. (B) Write down the equations of equilibrium at the knot A. (C) Determine the force developed in each cable for equilibrium.

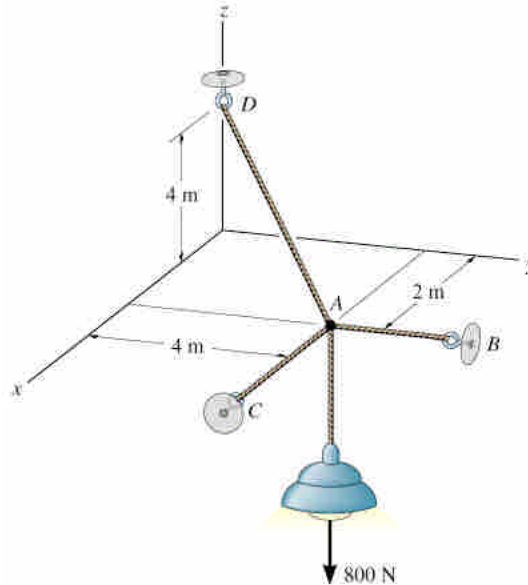

Fig. 4

5. The force  $\mathbf{F} = \{-40\mathbf{i} + 20\mathbf{j} + 10\mathbf{k}\}$  N acts at point A shown in Fig. 5. (A) Determine the moment of this force about the point O. (B) Determine the moments of this force about the x and a axes, respectively.

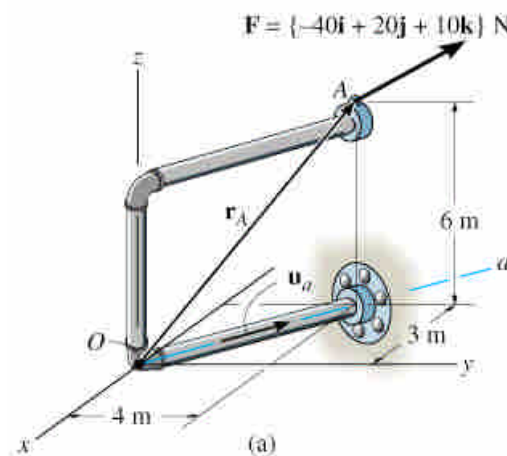

Fig. 5